

# Isolation Signal Splitter DN 22000

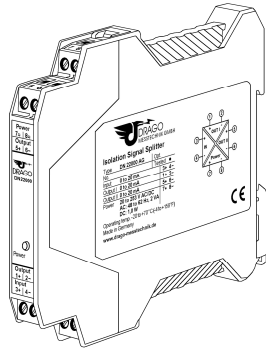

Read these instructions before using the product and retain for future information.

DN 22000

### 1. Before Startup



When operating the isolating signal splitter, certain parts of the module can carry dangerous voltage! Ignoring the warnings can lead to serious injury and/or cause damage!

The isolation signal splitter should only be installed and put into operation by qualified staff. The staff must have studied the warnings in these operating instructions thoroughly.

The isolation signal splitter may not be put into operation if the housing is open.

In applications with high working voltages sufficient distance and isolation as well as shock protection must be ensured.

Safe and trouble-free operation of this device can only be guaranteed if transport, storage and installation are carried out correctly and operation and maintenance are carried out with care.



Appropriate safety measures against electrostatic discharge (ESD) should be taken during range selection and assembly on the transmitter.

### 2. Short Description

The Isolation Signal Splitter DN 22000 is used for isolation, conversion and distribution of 0/4 ... 20 mA and 0 ... 5/10 V standard process signals. The input signal and two output signals each can be separately selected by the Order No.

The 4-Port-Isolation guarantees reliable decoupling of the sensor circuit from the processing circuit and prevents linked measurement circuits from influencing each other. The Protective Separation with high isolation level provides protection for personnel and downstream devices against impermissibly high voltage.

### 3. Functioning

The input signal is modulated and then electrically decoupled using a transformer. The isolated signal is then made available at two outputs, demodulated, filtered and amplified.

### 4. Mounting, Electrical Connection

The isolation amplifier is mounted on standard 35 mm DIN rail.

#### Terminal assignments

1 Output I +	5 Output II +
2 Output I -	6 Output II -
3 Input +	7 Power supply
4 Input -	8 Power supply

### 5. Block Diagram

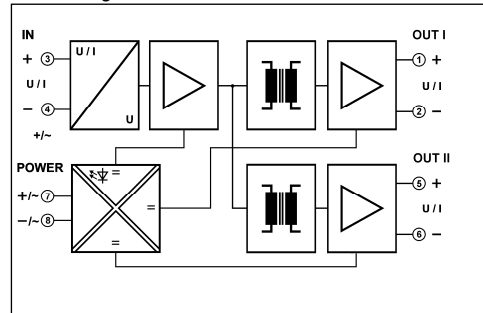

### 6. Technical Data

<b>Input</b>		
Input signal (see Product line)	0 ... 20 mA	0 ... 5 V
	4 ... 20 mA	0 ... 10 V
Input resistance	Current input 30 Ω	
	Voltage input 500 kΩ	
Overload	Current input ≤ 200 mA	
	Voltage input ≤ 30 V	
<b>Output</b>		
Output signal (see Product line)	0 ... 20 mA	0 ... 5 V
	4 ... 20 mA	0 ... 10 V
Load	Current output ≤ 500 Ω	
	Voltage output ≥ 2 kΩ	
Offset	20 μA, 10 mV	
Ripple	< 10 mV <sub>rms</sub>	
<b>General data</b>		
Transmission error	< 0.1% of final value	
Temperature coefficient <sup>1)</sup>	< 0.015% of final value / K	
Response time	< 5 ms	
Test voltage	2.5 kV, 50 Hz	
	input against output against power supply	
Working voltage <sup>2)</sup> (Basic insulation)	Up to 600 V AC/DC for overvoltage category II and pollution degree 2 acc. to EN 61010-1 between all circuits.	
Protection against dangerous body currents <sup>2)</sup>	Protective separation according to EN 61140 by reinforced insulation in accordance with EN 61010-1 up to 300 V AC/DC for overvoltage category II and pollution degree 2 between all circuits.	
Ambient temperature	Operation	-10 °C to +60 °C (+14 to 140 °F)
	Transport and storage	-20 °C to +80 °C (-4 to 176 °F)
Power supply (see Product line)	80 ... 240 V AC, ±10%, 48 ... 62 Hz	approx. 3 VA
	24 V DC (20 ... 30 V DC)	approx. 1.5 W
EMC <sup>3)</sup>	EN 61326 -1	
Construction	11,2 mm (0.44") housing, protection type: IP 20	
Connection	≤ 2.5 mm <sup>2</sup> , AWG 14	
Weight	Approx. 100 g	

- Average TC in specified operating temperature range
- As far as relevant the standards and rules mentioned above are considered by development and production of our devices. In addition relevant assembly rules are to be considered by installation of our devices in other equipments. For applications with high working voltages, take measures to prevent accidental contact and make sure that there is sufficient distance or insulation between adjacent situated devices.
- Minor deviations possible during interference

### 7. Order Information

Devices	Order No.
Isolation Signal Splitter	DN 22 - X X X - X
Power supply	80 ... 240 V AC
	24 V DC
Input	0 ... 20 mA
	4 ... 20 mA
	0 ... 5 V
	0 ... 10 V
Output I	0 ... 20 mA
	4 ... 20 mA
	0 ... 5 V
	0 ... 10 V
Output II	0 ... 20 mA
	4 ... 20 mA
	0 ... 5 V
	0 ... 10 V

Other signals on request.

### 8. Dimensions

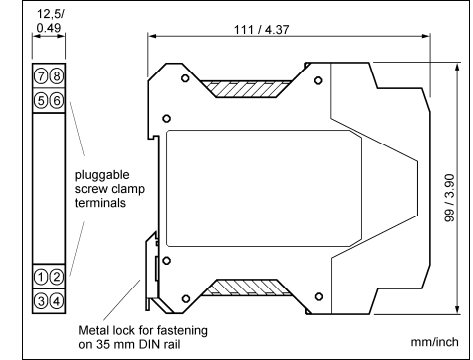

### DRAGO Messtechnik GmbH

Waldstrasse 86 - 90  
13403 BERLIN  
GERMANY

Phone: +49 (0)30 40 99 82 - 0  
Fax: +49 (0)30 40 99 82 - 10

E-Mail: info@drago-messtechnik.de  
Internet: www.drago-messtechnik.de